

# ***Red Sea MAX*** ***S-Series***

## *Installation & Operation Manual*

GB v.01.01



 **Red Sea**

# ***Red Sea MAX***

## *S-SERIES*

### *Installation & Operation Manual*

- 1. Introduction*
- 2. Safety*
- 3. Location*
- 4. Assembly*
- 5. Operation*
- 6. Maintenance*
- 7. Warranty*

## Introduction

Congratulations on your purchase of the **Red Sea MAX-S** complete reef system.

**Red Sea** developed the **MAX** to provide a complete reef spec system so that from the beginning, you can focus on the aquarium's inhabitants rather than the hardware.

The **Red Sea MAX** approach to the coral reef experience is to create an environment that is specifically attuned to the need of corals and all reef inhabitants on an artificial reef. In the ocean coral reefs flourish only where specific physical conditions prevail, such as sufficient light, adequate current, stable temperature and water clarity.

The **Red Sea MAX** provides a system that creates the conditions that enables you to keep a thriving, healthy reef in your own home.

This manual contains the installation and operational instructions for all of the **MAX-S** aquariums.

We hope that you enjoy your **MAX**.

## Safety

### PLEASE READ AND FOLLOW ALL SAFETY INSTRUCTIONS

**DANGER:** To avoid possible electric shock, special care should be taken when handling a wet aquarium. For each of the following situations, do not attempt repairs yourself; return the appliance to an authorized service facility for service or discard the appliance.

**WARNING:** To guard against injury, basic safety precautions should be observed, including the following:

Do not operate any appliance if it has a damaged cord or plug, if it is malfunctioning, or if it is dropped or damaged in any manner.

To avoid the possibility of the appliance plug or receptacle getting wet, position the aquarium stand and tank to one side of a wall mounted receptacle to prevent water from dripping onto the receptacle or plug. You should create a "drip loop" (see Figure 1) for each cord connecting an aquarium appliance to a receptacle. The "drip loop" is that part of the cord below the level of the receptacle, or the connector. Use an extension cord, if necessary, to prevent water traveling along the cord and coming into contact with the receptacle. If the plug or receptacle does get wet, DO NOT unplug the cord. Disconnect the fuse or circuit breaker that supplies power to the appliance. Then unplug the device and examine for presence of water in the receptacle.

Close supervision is necessary when any appliance is used by or near children.

To avoid injury, do not contact moving parts.

Always unplug an appliance from an outlet when not in use, before putting on or taking off parts, and before cleaning. Never pull the cord itself to remove the plug from the outlet. Grasp the plug and pull to disconnect.

Do not use an appliance for anything other than its intended use. The use of attachments not recommended or sold by the appliance manufacturer may cause an unsafe condition.

Do not install or store the appliance where it will be exposed to the weather or to temperatures below freezing point.

Make sure an appliance mounted on a tank is securely installed before operating it.

Read and observe all the important notices on the appliance.

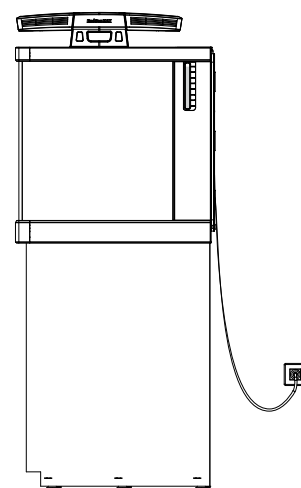

**Figure 1: Drip Loop**

**NOTE:** A cord rated for less amperes or watts than the appliance rating may overheat. Care should be taken to arrange the cord so that it cannot be tripped over or pulled accidental.

## Location

The first step in setting up the MAX-S is to choose a suitable location.

### Weight

The MAX-S aquariums are supported by 9 - 12 adjustable feet (depending on model). The flooring directly below the legs must be rated for a static loading of at least 15 kg/cm<sup>2</sup> (220 lbs/square inch).

### Room temperature

Site selection is important for correct temperature maintenance. We recommended that you keep the ambient room temperature a comfortable and stable 22°C / 72°F. Avoid placing the tank in front of an air conditioner, heating vents or direct sunlight. A well ventilated room with moderate light is the best place to position the aquarium.

### Accessibility

- **Back:** Ensure that there is at least 15cm / 6" of clearance behind the MAX to allow for operation and maintenance of the flow valve on the main downpipe as well as sufficient air circulation for a chiller.
- **Sides – Rear:** Ensure that there is sufficient room (approximately 60cm/24") between both sides of the aquarium and any adjacent walls or furniture for access to the rear of the tank. In addition to the regular maintenance of the surface skimmer, pumps and return flow vents of the rear chamber, specific access is required as follows: Left side - filling of Top-up water reservoir, installing/removing cables to power drawer. Right side – adjustment and maintenance of down-flow valve.
- **Sides – Front:** Ensure that there is approximately the length of the tank free on at least one of the sides. This is to enable the installation/replacement of the color trim on the tank as well as being able to replace the tubes in the front and rear light units without having to remove it from the aquarium.

### General considerations:

Ensure that the area surrounding the aquarium is waterproof and consider moving away anything that water might damage or may be corroded by the salt.

NOTE: The MAX-S system should not be moved when full of water.

## Assembly

Detailed instructions for the complete assembly of the MAX-S can be found in the accompanying graphic manual. It is important to assemble the MAX-S in the order indicated. The following information compliments the graphic manual.

If you are planning on pre-assembling the cabinet before transporting the MAX-S to its final location, complete only the stages 1 & 2 as per the graphic manual.

NOTE: Left and Right designations are when looking from the front of the Aquarium.

### Tools

The assembly requires the following tools:

- Adjustable torque Power Drill/Driver (at least 12V) with a crosshead bit on a 5cm/2" extension.  
**Do not use an impact power driver**
- Regular crosshead and flat screwdrivers
- Rubber Mallet
- Spirit level (at least 60cm/2')

### Components

- The **MAX-S** system includes the following main components:
- MAX-S type glass aquarium with integral top-up reservoir
- Cabinet (self-assembly)
- MAX-S T5 lighting unit
- Power Center
- Glass Sump including Filter sponges, Carbon media and Float valve for automatic top-up
- Internal Piping
- C-Skim 1800 Protein Skimmer
- Main return pump (size according to model)
- Circulation pumps (number according to model)

Color pack:

- Cabinet sides and doors
- Trim pack for aquarium, cabinet and lights

## Cabinet assembly

**WARNING: If you are not experienced in the construction of self assembly furniture, seek suitably qualified assistance.**

The parts of the frame are connected by screwing self-tapping screws through the corner brackets into pre-drilled holes in the aluminum profiles. This is best achieved by using a power drill with an adjustable torque. It is necessary to apply pressure when screwing self tapping screws into aluminum. To ensure that all screws of the frame are properly seated the manual shows turning the frame around during the various stages of assembly so that pressure can easily be applied by screwing downwards while the parts are supported by the floor.

When screwing into plastic parts such as the aquarium base board or the lower front plinth, use a hand screwdriver and not the power driver.

NOTE: The upper and lower plinths are part of the color trim pack.

The adjustable feet on the bottom of the cabinet enable the system to be leveled irrespective of the flatness of the floor. When assembled the height of the feet can be adjusted so that the bottom edge of the side panels will be 6 – 12mm (1/4" – 1/2") above the floor. Initially assemble the 4 corner feet to the highest position and all other feet to be touching the stainless steel foot plates.

## Placing Aquarium

Before placing the aquarium in its operating position familiarize yourself with top-up reservoir outlet, main pump and down pipe connections and the flow control valve that are located at the back right corner of the aquarium. Once the system is in its operating position approximately 15cm (6") from the wall, the valve and connectors are accessible from the side.

**WARNING:** Lifting the glass aquarium onto the cabinet will require at least 4 people. The top of the cabinet is approximately 92cm/36" from the floor. The table shows the approximate weights of the different models of MAX-S aquarium. Ensure that anyone lifting the aquarium is physically suitable for such an operation and has been instructed in the correct methods of lifting heavy objects.

Approximate weights of Aquarium Glass		
Model	Metric (kg)	Imperial (lb)
S-400	100	220
S-500	120	265
S-650	140	310

Aquarium must be lifted from the bottom.

Take care not to damage the plastic rim on the front and sides at the top and bottom of the glass. Some damage to the rim will not affect the assembling of the external color trim.

Before lifting aquarium, place the assembled cabinet in the final operating position (see location above) and set the glass aquarium in position on top.

The back of the glass should be flush with the rear edge of the cabinet top board. The front and sides of the glass should protrude slightly beyond the edges of the cabinet board such that the protrusion is approximately even on both sides. Incorrect positioning of the aquarium on the cabinet will interfere with the assembly of the color trim.

Once the aquarium is correctly aligned with the cabinet, check that the cabinet has not moved. If necessary readjust the position of the cabinet.

## Leveling Aquarium

The spirit level can be placed on the plastic rim that is around the top or bottom of the glass. To raise or lower the aquarium use the spanner provided to turn the bottom nut on the adjustable feet. The top nut is for locking the feet in position once the leveling is complete.

To level the aquarium start by adjusting the forward/ backward direction on both sides and only after both sides are level adjust the left/right alignment by raising or lowering both of the feet on one side.

When both directions are level, check that you are satisfied with the distance between the side panels and the floor. If necessary raise or lower all four corner feet until you achieve the desired distance. When satisfied with the height and leveling lock the four corner feet in position by raising the upper lock nut until tight against the steel foot plate.

Now lower each of the other feet until they are properly in contact with the floor (pay special attention when on carpet) and lock each one in position with the lock nut.

## Color Trim















The color trim pack contains a set of plastic parts that are painted to the designated color. Each trim pack has a corresponding color cabinet pack that includes the cabinet side panels and doors.

The trim pack includes; the upper and lower plinth that is part of the cabinet, the color trim for the upper and lower rim of the aquarium, the front panels and end caps for the lighting unit.

The color trim for the upper and lower rim of the aquarium and the front panel are fitted by sliding them on to their corresponding part on the aquarium or light. In the event that the trim does not slide smoothly carefully push the trim into position by tapping the end with the rubber mallet.

## Cable identification labels

Before installing lights, pumps, skimmer or additional equipment on the aquarium place the identifier labels on the cables near to the plug. The icons on the cable labels correspond to the icons for the switches and outlets of the power center.

	<b>Skimmer</b>		<b>Main Pump</b>		<b>Front T5x4 light</b>
	<b>Chiller</b>		<b>Circulation Pump 1</b>		<b>Center T5x2 Daylight</b>
	<b>Accessory 1</b>		<b>Circulation Pump 2</b>		<b>Center LED Moonlight</b>
	<b>Accessory 2</b>		<b>Circulation Pump 3</b>		<b>Front T5x4 light</b>
	<b>Heater</b>		<b>Circulation Pump 4</b>		



## Sump, pumps and piping

Feature \ Model	S-400	S-500	S-650
Number of circulation pumps	2	3	4
Main Pump L/Hr (gph)	6500 (2000)	9000 (2400)	9000 (2400)
Main pump feeds Chiller	Yes	Yes	No
Chiller return pipe provided	No	Yes	Yes
Plugged outlet for additional reactor	No	Yes	Yes
Space in sump for additional reactor	No	Yes	Yes

**Top up water reservoir outlet connector** – Remove the outlet connector by rotating it anti-clockwise. Pass the grey tube through the cut-out in the aquarium base and attach it to the hose-barb of the outlet. Before returning the outlet to the reservoir, ensure that the O-ring is in place. Rotate the outlet connector clockwise firmly to ensure a good seal.

**Top up water in-line flow valve and float valve** - During installation set the flow valve in the fully closed position and the float valve to give the lowest water level in the pump chamber.

**Piping** - Ensure that the O-rings are in place before connecting the universal connectors for the piping. During installation it is recommended to set the sump piping valves in the closed position. They should only be opened after the downstream equipment such the skimmer or chiller has been installed.

**Main Pump** – install the 32mm (1½”) elbow on the inlet of the pump so that water intake is from the bottom of the sump. Pass the power cable through the cut out at the top rear left corner of the sump compartment.

**Skimmer** – Ensure that the skimmer shelf is installed in the sump with the rubber side up. Full installation and operation instructions for the C-Skim 1800 protein skimmer are provided in a dedicated instruction manual. Initially set the air valve on the skimmer to the closed position. Pass the power cable through the cut out at the top rear left corner of the sump compartment.

**Carbon** - Wash the carbon filter material under running water several times to remove residual dust. It is recommended to soak it in water for 24-72 hr. before usage otherwise during the first 3 days after set-up the carbon may float and release micro air bubbles from inside its pores.

## Lighting

The **MAX-S** lighting system is designed specifically for the **MAX-S** aquariums and should be used in conjunction with the MAX-S power center. To ensure its overall safety each component of the system is locked in place on the lighting chassis and is protected by an automatic circuit breaker on the power center. The system consists of identical front and rear 4xT5 units and a center unit with 2xT5 plus LED moonlights. The Daylight and Moonlight circuits of the center unit have individual power cables for connection to the power center.

Prepare each of the units as shown in the manual and test them before mounting on the lighting chassis. Note: The front and rear 4 x T5 units have a micro-switch on the left side. The micro-switch needs to be pressed for the lights to work during testing.

The complete lighting unit is designed to slide easily front/back and the front and rear 4xT5 units can be raised to the upright position to give full access to the top of the aquarium. The 4xT5 units automatically switch off when raised. **WARNING:** Do not slide with the 4xT5 units in the raised position. In the event of accidental fall, remove side trim and inspect end caps and chassis for damage.

After mounting the individual light units on the Light Chassis thread the cables through the chassis end plates (as shown in the graphic instruction manual) and through the cable holders on the top rear surface of the aquarium. In order to be able to easily slide the light unit to the front of the tank allow for a bit of extra cable between the chassis and the cable holders.

NOTE: After assembly the rear bottom edge of the chassis color trim holds the cables in the correct position. Hold the cables down while assembling the chassis trim.

## Power Center

Assemble the Power Center (PC) drawer in the cabinet by laying the drawer on the sliders and push into position. There are 2 catches on the underside of the drawer that "click" when the drawer is attached properly to the sliders. To remove the drawer, release the 2 catches on the underside of the drawer and pull the drawer off of the sliders.

The PC includes 3 individual power strips, each of which can be removed for service without affecting the functionality of the others. Each strip is protected by a resettable thermal circuit breaker which will only neutralize the specific strip. The left and right strips are identical and provide 5 individually switched outlets on each. The center strip is the lighting controller and includes 2 analog timers allowing for a sunrise/sunset effect as well as an automatic switchover to the moonlights when the daylights are switched off. The main switch on the front panel shuts down the complete strip however this also stops the timers.





Connect the main power cable to the inlet socket of the left strip and direct the cable out of left slot on the back of the drawer. Ensure that all of the switches on the front panel are in the off position. Do not connect the main power cable to the power until the aquarium and sump are filled with water.

To connect equipment to the PC:

**IMPORTANT:** Before opening the PC ensure that your hands are dry and that there is no water dripping down the front glass of the aquarium.

1. Make sure that the lid is in the closed position (pulled to the front of the drawer) and that the drawer is in its normal operating position. All equipment is attached from the rear of the drawer.
2. Place plugs into the back section of the drawer with the cables running through one of the slots.
3. Open the drawer as far as it will go and slide the lid backwards.
4. Reach into the back of the draw and gently pull the plugs forward.
5. Insert each plug into its designated outlet.
6. Close the lid (pulled to the front of the drawer) and return the draw to its normal operating position.
7. Make sure that all of the cables at the back of the drawer are free to move as the drawer is opened and closed.

### Connecting the Lighting unit to the PC:

Plug the LED moonlights into outlet #3.		#1. Right Timer Daylight
Choose from the 3 daylight units (front or rear 4 x T5 or center 2 x T5) for the longer photoperiod (i.e. first on and last off) and plug the selected unit into outlet #4.		#2. Right Timer Daylight
Plug the remaining 2 units into the outlets #1 & #2.		#3. Left Timer Moonlight
Outlet #5 is not connected to the timers and is suitable for a utility light inside the cabinet.		#4. Left Timer Daylight
		#5. Cabinet Light (not provided)

### Heaters, Chillers and other accessories

Heaters and Chillers are not provided as a standard part of the MAX-S however preparations have been made for their installation.

Dedicated power outlets are provided for a heater, chiller and 2 accessories in the Power center.

**Chiller:** The left hand compartment under the power center has been designed to house a chiller. A gap has been provided between the base board and door and the rear has been left open to allow for proper airflow for the chiller to run without overheating. The inlet and outlet pipes of the chiller should pass through the cut out at the top rear left corner of dividing wall between the sump and chiller compartments.

**S-400:** Connect the inlet pipe of the chiller to the chiller outlet on the main pump manifold. Place the return pipe from the chiller into the downpipe chamber of the sump with the return pipe ending under the water. Once the complete system is operational set the chiller flow valve for a flow of approximately 2000 l/h (500gph).

**S-500:** Connect the inlet pipe of the chiller to the chiller outlet on the main pump manifold. Connect the outlet of the chiller to the inlet of the chiller return pipe that is attached to the rear wall of the sump compartment. Add an extra piece of flexible pipe from the outlet of the chiller return pipe to the downpipe chamber of the sump with the flexible pipe ending under the water. Once the complete system is operational set the chiller flow valve for a flow of approximately 2000 l/h (500gph).

Heaters and other accessories (such as a calcium reactor) can be placed in the accessory compartment (left side) of the sump. Water to feed accessories can be taken by replacing the  $\frac{3}{4}$ " plug in the main pump manifold with a suitable hose barb.

**S-650:** Place a 2400 l/h (600gph) feeding pump for the chiller in the accessory compartment (left side) of the sump and connect with flexible piping to the inlet of the chiller. Connect the outlet of the chiller to the inlet of the chiller return pipe that is attached to the rear wall of the sump compartment. Add an extra piece of flexible pipe from the outlet of the chiller return pipe to the downpipe chamber of the sump with the flexible pipe ending under the water.

Heaters and other accessories (such as a calcium reactor) can be placed in the accessory compartment. Water to feed accessories can be taken by replacing the  $\frac{3}{4}$ " plug in the main pump manifold with a suitable hose barb and adjusting the flow as required with the valve.

## Operation

### MAX-S Aquarium Flow Dynamics Overview

The MAX-S aquarium is divided into 3 parts: Main Tank, Rear Chamber and Top-up Reservoir.

The main tank and rear chamber are connected by a surface skimmer across the top of most of the length of the tank and a number of flow holes located along the back wall.

The silent-flow downpipe system includes a transparent funnel with a flow-regulated main downpipe and a secondary overflow pipe that is 25mm (1") above the main downpipe. The fine adjustment flow valve allows for the water level in the rear chamber to be maintained at a constant height without hearing the water returning to the sump. In the event of a change in flows or blockage in the main downpipe the overflow pipe will accommodate all of the water flow to the sump. An incorrect setting of the flow valve will be accompanied by the sound of the water returning to the sump and is an indication that the flow valve needs adjusting.

When all of the circulation pumps are running and the flow valve is adjusted correctly the water in the main tank will always be maintained just below the bracing bars but above the external trim so the water line in the aquarium will never be visible from the outside. The water level in the rear chamber will be maintained approximately 30mm (1¼") below the water level in the main tank ensuring a positive surface skimming at all times. The height of the water in the rear chamber can be monitored through the viewing slot at the top of the side panel on the right side of the chamber or by lifting the flap above the funnel.

Any loss of water due to evaporation will cause a drop in the water level of the sump. The float valve in the main pump compartment of the sump controls the automatic replenishment of top-up water from the reservoir. The reservoir contains water for approximately 5 days of evaporation. Top-up water is added to the reservoir at the top left corner of the rear chamber. The water level in the reservoir can be monitored through the viewing slot at the bottom of the side panel on the left side of the chamber.

In the sump all water passes through 2 mechanical sponge filters before flowing into the skimmer and accessory chambers. All of the water then passes through the carbon filter media before entering the main pump chamber.

The main pump returns the water to the aquarium and a regulated portion of the flow is provided for the skimmer and in the 400/500 also to the chiller.

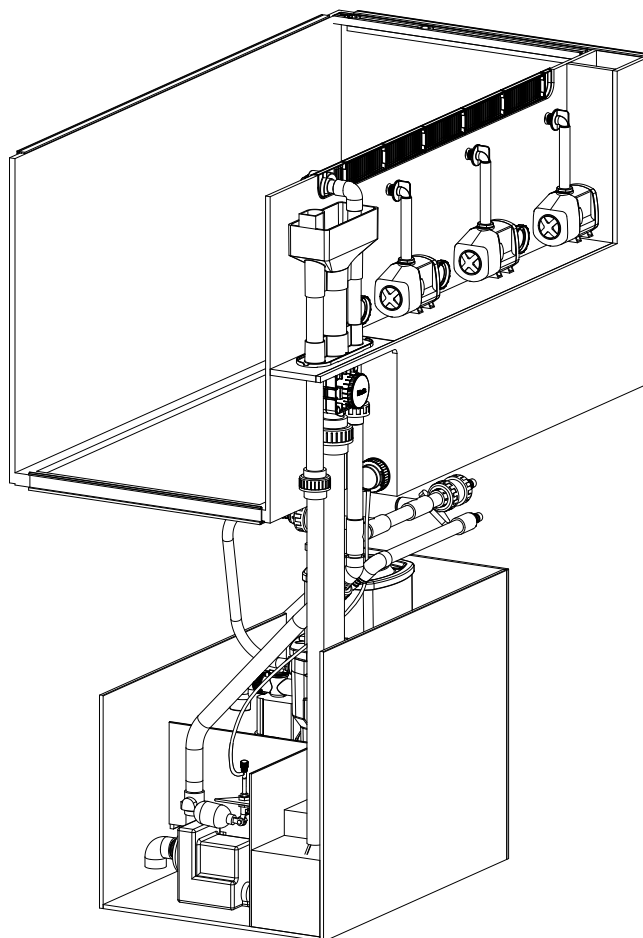

## Initial Fill

Open the main flow valve (rotate anti-clockwise) to maximum.

Add water to the main tank and rear chamber and when the water is above the level of the circulation pump outlets switch them on.

Continue adding water to the main tank. Open the cabinet door and monitor the water level in the sump as it begins to fill. As soon as there is approximately 15 cm (6") of water in the main pump compartment switch on the main pump and stop adding water.

Allow the system to run for a few minutes and try to adjust the flow valve so that the water level in the rear chamber is approximately at the dotted line.

Open the valves to the skimmer (initially approximately 50% open) and any other equipment that takes water from the sump and readjust the flow valve.

Add more water to the system until the water level in the main pump chamber of the sump is approximately 20cm (8").

**WARNING:** overfilling the sump may cause a flood in the event of an interruption of electricity.

**NOTE:** It is advisable to do the first fill with fresh water or a weak saltwater solution to check the integrity of the system and to clear away any chemical residues from production.

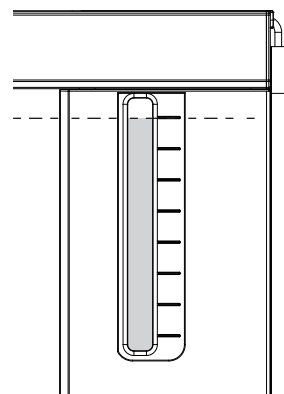

## Automatic Top-up System

Once the saltwater system is stable and the water height in the main pump chamber is approximately 20cm (8") adjust the angle of the float so that the valve is closed at the desired water height. Ensure that the Top-up flow valve is fully closed.

Fill the Top-up reservoir with RO water. For easy access to the fill port of the reservoir raise the rear 4xT5 light unit to the upright position and fully open the fill port flap.

Disconnect the top-up flow valve from the float valve and slowly open the flow valve until the top-up water drips at a rate of approximately 1 drop per second. Reconnect the flow valve to the float valve.

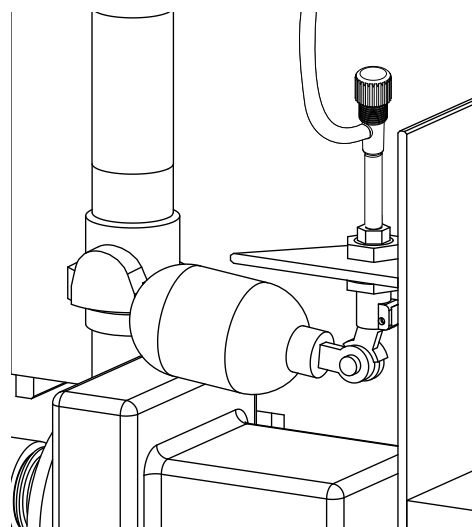

## Main Downpipe Flow Valve

The main downpipe flow valve provides a very fine control of the flow rate however after making adjustments it takes the system a few minutes to stabilize at the new setting. Once you have established the approximate setting for the valve make very small adjustments and wait for a few minutes each time. It may take a number of occasional adjustments to reach a stable level. When set properly this system removes all of the noise of water flowing down to the sump.

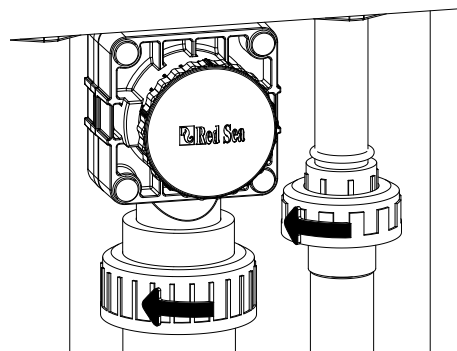

### Maintenance of flow valve

To disassemble the valve, switch off all of the pumps and allow the water level in the rear chamber to drop below the rim of the transparent funnel. Once the main downpipe is clear of water, remove the 4 rubber plugs from the corners and unscrew the 4 screws with the Allan key provided. Maintain the valve assembly vertical and pull it away from the valve body. Be careful not to let the screws fall out.

In the event of calcium deposits clean both the valve body and diaphragm with a weak acidic solution (e.g. vinegar) and rinse thoroughly after treatment.

When reassembling the valve assembly on the body, ensure that all 4 screws are tight enough to give a watertight seal however do not use excessive force. Replace the rubber plugs.

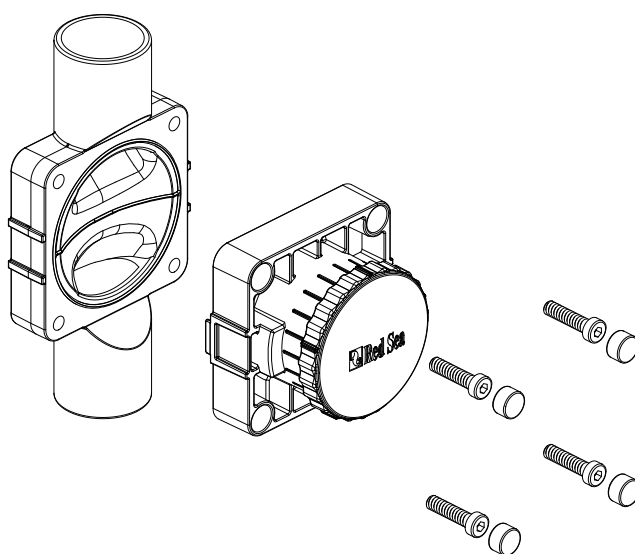

To replace the diaphragm rotate the handle clockwise and when free of the body remove the retaining pin. To reassemble rotate the handle in the opposite direction until the diaphragm is fully retracted.

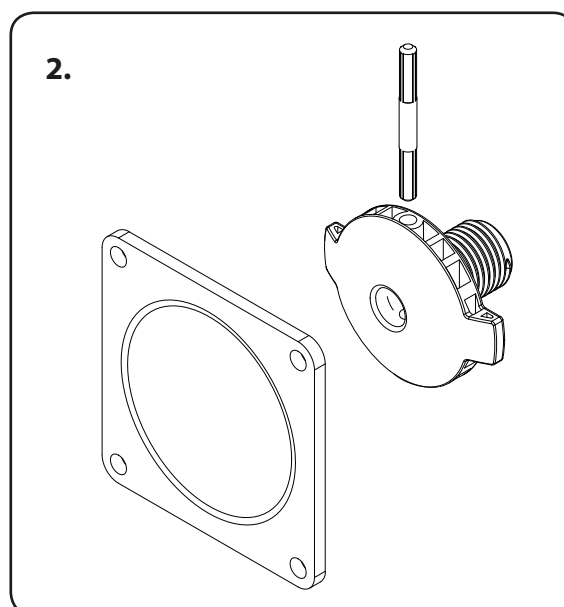
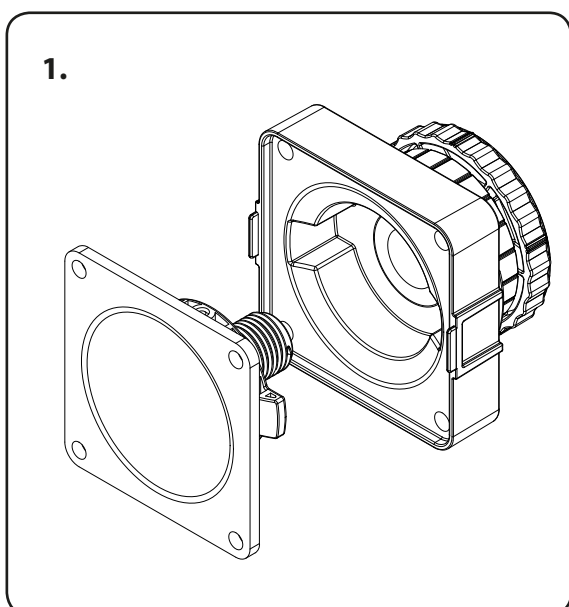

## Maintenance

The long-term success and health of the inhabitants of your **MAX** aquarium depends on you. Proper planning makes reef care easier to manage and quicker to perform. This will leave you more time for the real goal: enjoying your aquarium. Care of the tank should follow a regular, logical pattern. Divide the tasks into daily, weekly and monthly procedures, including equipment checks, feeding, water parameter testing and adjustments.

**You may find it helpful to make a systematic checklist of care activities and keep a log of the activities performed. Your log does not need to be complicated; you will need to track the following:**

- The tank's parameters – pH, salinity, temperature, etc.
- Information specific to each animal – when you added them, their approximate size, date of death (it happens in the most successful aquaria!) and possible cause, etc.
- The general appearance of the tank and individual species.
- Equipment changes – when you changed light tubes or replaced heaters, etc.

**Circulation** - Maintain adequate water circulation by checking that the circulation pumps are working well and are pointed in the right directions. If you notice any regression in currents, check the inlet of each pump and the outlet nozzles for any obstructions (snails, crabs, carbon chips, etc.).

**Protein skimmer functioning** - Check the foam production in the collection cup and adjust the water and air flow valve as required to get stable dry foam.

**Water levels** - Check daily the water level in the rear chamber and adjust the flow valve as required. Check the water level in the Top-up reservoir. Check the water level in the sump. Check that the top-up float valve is operating correctly.

**Water temperature control** - For optimum conditions a reef aquarium should be maintained at a stable water temperature in the range of 24-28°C / 76-82°F (the stability of the temperature being more important than the exact value). Slightly higher temperatures can be tolerated for short periods of time as long as the change in temperature is steady and not sudden. Monitor the temperature at least twice a day, looking for dramatic fluctuations.

Avoid temperature differences of more than 2°C / 7°F during the day. During season changes and when heating or cooling the house, monitor the tank temperature more frequently, adjusting the heater/chiller as necessary.

**Change the carbon filter** - Replace the active carbon filter every two months.

**Clean the pump impellers and housing** - Calcium carbonate builds up on the pump motors. Every 3 months, submerge each pump in a mixture of hot water and vinegar. Remember to properly turn off and disconnect each pump.

**Change the lamps** - Over 6-12 months, the intensity of the fluorescent lamps will decrease as much as 50% and the spectrum will narrow towards the red end, which can promote algae bloom.

Refer to the graphic assembly manual for inserting replacement tubes. Always switch off the complete lighting controller at the Power Center before doing any maintenance work on the lights.

The Center 2xT5 unit must be removed from the light chassis to replace the lamps.

The lamps of the front and rear 4xT5 units can be replaced while assembled on the chassis. Raise the 4xT5 unit to the upright position. Remove the color trim cover from one of the ends and slide the transparent lens out of the unit.

## Warranty

### Red Sea Aquarium Products Limited Warranty.

The limited warranty sets forth all **Red Sea Aquatics (HK) Ltd (Red Sea)** responsibilities regarding this product. There are no other express or implied warranties from **Red Sea**.

**Red Sea** warrants your product against defects in materials and workmanship for a period of 12 months, valid from the date of original purchase and will repair this product free of charge (not including shipping costs) with new/rebuilt parts. Damage to the aquarium glass or to the florescent tubes is not included. The precondition for the warranty is that the stipulated set-up routine is observed. In the event that a problem develops with this product during or after the warranty period, contact your local dealer or **Red Sea** (at the company address indicated) for details of your nearest authorized service center.

The warranty is extended only to the original purchaser. Proof of date of purchase will be required before warranty performance is rendered. This warranty only covers failures due to defects in materials or workmanship which occur during normal use. It does not cover damage which occurs in shipment or failures which result from misuse, abuse, neglect, improper installation, operation, mishandling, misapplication, alteration, modification or service by anyone other than an authorized **Red Sea** service center.

**Red Sea** shall not be liable for incidental or consequential damages resulting from the use of this product, or arising out of any breach of this warranty. All express and implied warranties, including the warranties of saleability and fitness for particular purpose, are limited to the applicable warranty period set forth above.

These statements do not affect the statutory rights of the consumer.

### USA

Some states do not allow the exclusion or limitation of incidental or consequential damages, or limitations on how long an implied warranty lasts, so the above exclusion or limitations may not apply.





[www.redseafish.com](http://www.redseafish.com)

**Red Sea U.S.A**  
18125 Ammi Trail  
Houston, TX 77060  
Tel: 1-888-RED-SEA9  
[redseainfo@redseafish.com](mailto:redseainfo@redseafish.com)

**Red Sea Europe**  
ZA de la St-Denis  
F-27130 Verneuil s/Avre,  
France  
Tel: (33) 2 32 37 71 37  
[info@redseaeurope.com](mailto:info@redseaeurope.com)

**Red Sea Aquatics (UK) Ltd**  
PO Box 1237  
Cheddar, BS279AG  
T: +44 (0) 203 3711492  
F: +44 (0) 800 0073169  
[sales.uk@redseafish.com](mailto:sales.uk@redseafish.com)

**Red Sea Deutschland**  
Büro Deutschland  
Prinzenallee 7 (Prinzenpark)  
40549 Düsseldorf  
Tel: 0211-52391 481  
[de.info@redseafish.com](mailto:de.info@redseafish.com)